

HOB DATA	
DP / MODULE	= 1.4624
N PA	= 18°
N. of Threads	= 3- THD
Hand of Thread	= RIGHT HAND
Lead Angle	= 3°52'
Lead Normal	= 13.78279
Lead Axial	= 13.81424
WD	= 4.166
NO. of gashes	= 16
Gashes	= STRAIGHT
Flute Incl. Angle	= 30°
Grove Lead	= OO
Hob Class	= DIN3968 'AA'
Cam	= 2.03

NORMAL VIEW
TOP COMING
FINISHING
NON- TOPPING

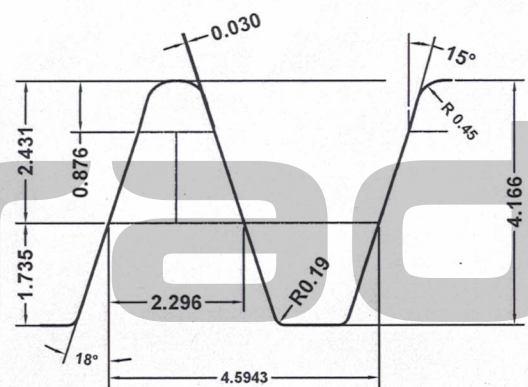

HOB TOOTH NORMAL SECTION

REFERENCE DATA
**** DRG #

Własność intelektualna firmy:
Tradensa Sp. z o. o.
Ul. Urocza 5a, 62-081 Wysogotowo
NIP: 781-20-22-828
KRS: 0000910290

HOB MARKING

CTMS
1.4624 MOD , 18° PA ,
WD 4.166 , 3 START , RH
LA = 3°52' , GL : OO
CLASS ' AA' , S-390
OP-18003-1 TO OP-18003-10

DRN.	Cheema	P.O. No.
CHKD.	BHAGWAN S.	#
DATE	02.07.15	APPROVED
DIMENSION INCHES / MM		
THIRD ANGLE PROJECTIN		

CAPITAL TOOL INDUSTRIES PATIALA (INDIA)	
DESCRIPTION.	DRG NO. CTI - 015 - 0702
HSS S-390 MATERIAL 1.4624 MOD , 18° PA 4.166 mm WD , PRE-SHAVE HOB PROFILE 3- START , RIGHT HAND , NT , CL 'AA'	REV.
	CUSTOMER CTMS